

SPECIFICATIONS

HX235 LCR

ENGINE			
Maker / Model		CUMMINS QSB6.7 Engine	
Type		Water-cooled, 4-cycle diesel, 6-cylinder in-line, Direct injection, Turbocharged, Charge air cooled, Low emission	
Rated flywheel horse power	SAE	J1995 (gross)	136 kW (183 HP) at 1,950 rpm
		J1349 (net)	129 kW (173 HP) at 1,950 rpm
	DIN	6271/1 (gross)	136 kW (185 PS) at 1,950 rpm
		6271/1 (net)	129 kW (175 PS) at 1,950 rpm
Max. torque		81.6 kgf (590 lbf.ft) at 1,500 rpm	
Bore x stroke		107 x 124 mm (4.2" x 4.9")	
Piston displacement		6,700 cc (409 cu in)	
Batteries		2 x 12 V x 100 Ah	
Starting motor		24 V - 4.8 kW	
Alternator		24 V - 95 A	

HYDRAULIC SYSTEM

MAIN PUMP	
Type	Variable displacement tandem axis piston pumps
Max. flow	2 x 222 l/min (58.6 US gpm / 48.8 UK gpm)
Sub-pump for pilot circuit	Gear pump

Cross-sensing and fuel saving pump system

HYDRAULIC MOTORS	
Travel	Two speed axial pistons motor with brake valve and parking brake
Swing	Axial piston motor with automatic brake

RELIEF VALVE SETTING	
Implement circuits	350 kgf/cm ² (4,980 psi)
Travel	350 kgf/cm ² (4,980 psi)
Power boost (boom, arm, bucket)	380 kgf/cm ² (5,410 psi)
Swing circuit	285 kgf/cm ² (4,050 psi)
Pilot circuit	40 kgf/cm ² (570 psi)
Service valve	Installed

HYDRAULIC CYLINDERS	
No. of cylinder bore x stroke	Boom: 2-120 x 1,290 mm
	Arm: 1-140 x 1,510 mm
	Bucket: 1-120 x 1,055 mm
	Dozer Blade: 2-130 x 240 mm
	2-Piece Boom: 1st: 2-125 x 1,260 mm 2nd: 1-160 x 1,060 mm

DRIVES & BRAKES	
Drive method	Fully hydrostatic type
Drive motor	Axial piston motor, in-shoe design
Reduction system	Planetary reduction gear
Max. drawbar pull	20,500 kgf (45,194 lbf)
Max. travel speed (high / low)	5.5 km/hr (3.5 mph) / 3.3 km/hr (2.1 mph)
Gradeability	35° (70%)
Parking brake	Multi wet disc

CONTROL

Pilot pressure operated joysticks and pedals with detachable lever provide almost effortless and fatigueless operation.

Pilot control	Two joysticks with one safety lever (LH): Swing and arm (RH): Boom and bucket (ISO)
Traveling and steering	Two levers with pedals
Engine throttle	Electric, Dial type

SWING SYSTEM

Swing motor	Fixed displacement axial piston motor
Swing reduction	Planetary gear reduction
Swing bearing lubrication	Grease-bathed
Swing brake	Multi wet disc
Swing speed	10.8 rpm

SERVICE REFILL CAPACITIES

	liter	US gal	UK gal
Re-filling			
Fuel tank	320	84.5	70.4
Engine coolant	40	10.6	8.8
Engine oil	23.7	6.3	5.2
Swing device	7	1.8	1.5
Final drive (each)	4.5	1.2	1.0
Hydraulic system (including tank)	275	72.6	60.5
Hydraulic tank	160	42.3	35.2
DEF/AdBlue® tank	27	7.1	5.9

UNDERCARRIAGE

The X-leg type center frame is integrally welded with reinforced box-section track frames. The undercarriage includes lubricated rollers, idlers, track adjusters with shock absorbing springs and sprockets and a track chain with double or triple grouser shoes.

Center frame	X - leg type
Track frame	Pentagonal box type
No. of shoes on each side	49 EA
No. of carrier roller on each side	2 EA
No. of track roller on each side	9 EA
No. of rail guard on each side	2 EA

OPERATING WEIGHT (APPROXIMATE)

Operating weight, including 5,680 mm (18' 8") boom; 2,920 mm (9' 7") arm; SAE heaped 0.80 m³ (1.05 yd³) bucket, lubricant, coolant, full fuel tank, full hydraulic tank and all standard equipments.

OPERATING WEIGHT			
Shoes		Operating weight	Ground pressure
Type	Width mm (in)	kg (lb)	kgf / cm ² (psi)
Triple grouser	600 (24")	24,000 (52,910)	0.51 (7.25)
	700 (28")	24,280 (53,530)	0.44 (6.26)
	800 (32")	24,560 (54,140)	0.39 (5.55)
	900 (36")	24,840 (54,760)	0.35 (4.98)

BUCKET SELECTION GUIDE & DIGGING FORCE

HX235 LCR

BUCKETS

All buckets are welded with high-strength steel.



SAE heaped
m³ (yd³)

0.51 (0.67)



0.80 (1.05)
0.87 (1.14)
0.92 (1.20)

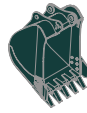

1.10 (1.44)
1.20 (1.57)

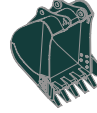

1.34 (1.75)



◆ 0.74 (0.97)
◆ 0.90 (1.18)
◆ 1.05 (1.37)



● 0.87 (1.14)

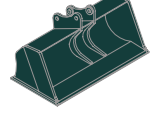

■ 0.75 (0.98)

Capacity m ³ (yd ³)		Width mm (in)		Weight kg (lb)	Recommendation mm (ft.in)					
					5,680 (18' 8") Mono-boom			5,650 (18' 6") 2-Piece boom		
SAE heaped	CECE heaped	Without side cutters	With side cutters		2,000 (6' 7") Arm	2,400 (7' 10") Arm	2,920 (9' 7") Arm	2,000 (6' 7") Arm	2,400 (7' 10") Arm	2,920 (9' 7") Arm
0.51 (0.67)	0.45 (0.59)	700 (27.6)	820 (32.3)	570 (1,260)	●	●	●	●	●	●
0.80 (1.05)	0.70 (0.92)	1,000 (39.4)	1,120 (44.1)	700 (1,540)	●	●	●	●	●	■
0.87 (1.14)	0.75 (0.98)	1,090 (42.9)	1,210 (47.6)	740 (1,630)	●	●	■	●	●	■
0.92 (1.20)	0.80 (1.05)	1,150 (45.3)	1,270 (50.0)	770 (1,700)	●	●	■	●	●	▲
1.10 (1.44)	0.96 (1.26)	1,320 (52.0)	1,440 (56.7)	830 (1,830)	●	■	▲	■	■	▲
1.20 (1.57)	1.00 (1.31)	1,400 (55.1)	1,520 (59.8)	850 (1,870)	■	▲	-	■	▲	-
1.34 (1.75)	1.15 (1.50)	1,550 (61.0)	1,670 (65.7)	920 (2,030)	▲	▲	-	▲	-	-
◆ 0.74 (0.97)	0.65 (0.85)	985 (38.8)	-	770 (1,700)	●	●	●	●	●	■
◆ 0.90 (1.18)	0.80 (1.05)	1,095 (43.1)	-	810 (1,790)	●	●	■	●	●	▲
◆ 1.05 (1.37)	0.92 (1.20)	1,290 (50.8)	-	890 (1,960)	●	■	▲	■	■	▲
● 0.87 (1.14)	0.75 (0.98)	1,140 (44.9)	-	900 (1,980)	●	●	■	●	●	▲
■ 0.75 (0.98)	0.65 (0.85)	1,790 (70.5)	-	880 (1,940)	●	●	■	●	●	▲

- ◆ Heavy duty bucket
- Rock-Heavy duty bucket
- Slope finishing bucket

- : Applicable for materials with density of 2,000 kg /m³ (3,370 lb/ yd³) or less
- : Applicable for materials with density of 1,600 kg /m³ (2,700 lb/ yd³) or less
- ▲ : Applicable for materials with density of 1,100 kg /m³ (1,850 lb/ yd³) or less

ATTACHMENT

Booms and arms are welded with a low-stress, full-box section design.

5.68 m (18' 8") Mono-boom and 5.65 m (18' 6") 2-Piece boom and 2.0 m (6' 7"); 2.4 m (7' 10") & 2.92 m (9' 7") Arms are available.

DIGGING FORCE

Arm	Length	mm (ft.in)	2,000 (6' 7")	2,400 (7' 10")	2,920 (9' 7")	Remarks:
	Weight	kg (lb)	975 (2,150)	1,045 (2,300)	1,095 (2,410)	
Bucket digging force	SAE	kN	133.4 [144.8]	133.4 [144.8]	133.4 [144.8]	[]: Power Boost
		kgf	13600 [14770]	13600 [14770]	13600 [14770]	
		lbf	29980 [32550]	29980 [32550]	29980 [32550]	
	ISO	kN	152.0 [165.0]	152.0 [165.0]	152.0 [165.0]	
		kgf	15500 [16830]	15500 [16830]	15500 [16830]	
		lbf	34170 [37100]	34170 [37100]	34170 [37100]	
Arm crowd force	SAE	kN	144.2 [156.5]	119.6 [129.9]	102.0 [110.7]	
		kgf	14700 [15960]	12200 [13250]	10400 [11290]	
		lbf	32410 [35190]	26900 [29210]	22930 [24900]	
	ISO	kN	151.0 [164.0]	125.5 [136.3]	106.9 [116.1]	
		kgf	15400 [16720]	12800 [13900]	10900 [11830]	
		lbf	33950 [36860]	28220 [30640]	24030 [26090]	

Note : Arm weight includes bucket cylinder, linkage and pin

DIMENSIONS & WORKING RANGE

HX235 LCR

HX235 LCR DIMENSIONS

5.68 m (18' 8") Mono-boom and 2.0 m (6' 7"), 2.4 m (7' 10") & 2.92 m (9' 7") Arm.

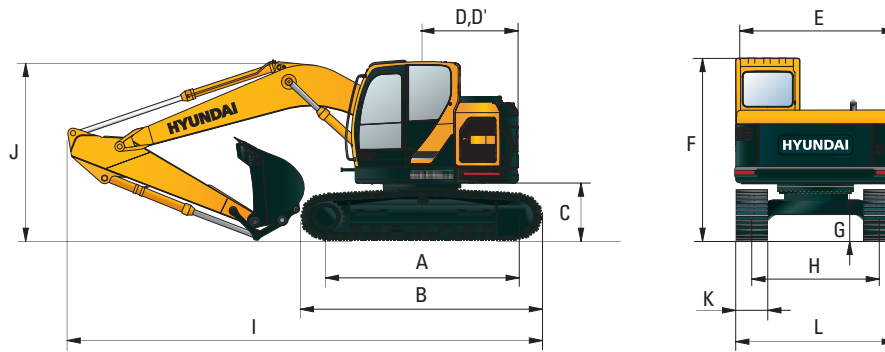

Unit : mm (ft-in)

A	Tumbler distance	3,650 (12' 0")
B	Overall length of crawler	4,404 (14' 6")
C	Ground clearance of counterweight	1,080 (3' 7")
D	Tail swing radius	1,780 (6' 04")
D'	Rear-end length	1,780 (6' 04")
E	Overall width of upperstructure	2,980 (9' 9")
F	Overall height of cab	3,290 (10' 10")
G	Min. ground clearance	480 (1' 7")
H	Track gauge	2,390 (7' 10")

Boom length	5,680 (18' 8")			
Arm length	2,000 (6' 7")	2,400 (7' 10")	2,920 (9' 7")	
I Overall length	9,040 (29' 8")	8,950 (29' 4")	8,910 (29' 3")	
J Overall height of boom	3,200 (10' 6")	3,100 (10' 2")	3,020 (9' 11")	
K Track shoe width	600 (24")	700 (28")	800 (32")	900 (36")
L Overall width	2,990 (9' 10")	3,090 (10' 2")	3,190 (10' 6")	3,290 (10' 10")

HX235 LCR WORKING RANGE

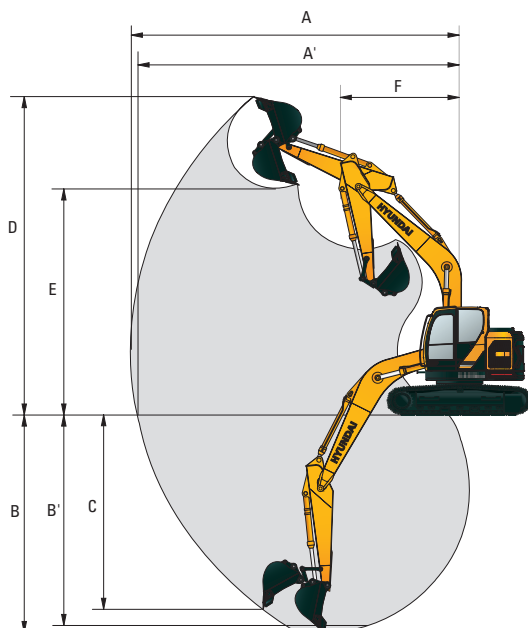

Unit : mm (ft-in)

Boom length	5,680 (18' 8")		
Arm length	2,000 (6' 7")	2,400 (7' 10")	2,920 (9' 7")
A Max. digging reach	9,040 (29' 8")	9,430 (30' 11")	9,910 (32' 6")
A' Max. digging reach on ground	8,860 (29' 1")	9,260 (30' 5")	9,750 (32' 0")
B Max. digging depth	5,780 (19' 0")	6,180 (20' 3")	6,700 (22' 0")
B' Max. digging depth (8' level)	5,550 (19' 0")	5,980 (19' 7")	6,530 (21' 5")
C Max. vertical wall digging depth	5,140 (16' 10")	5,710 (18' 9")	6,270 (20' 7")
D Max. digging height	10,090 (33' 1")	10,420 (34' 2")	10,830 (35' 6")
E Max. dumping height	7,190 (23' 7")	7,510 (24' 8")	7,890 (25' 11")
F Min. front swing radius	2,860 (9' 5")	2,550 (8' 4")	2,350 (7' 9")

DIMENSIONS & WORKING RANGE

HX235 LCR

HX235 LCR (DOZER TYPE) DIMENSIONS

5.68 m (18' 8") Mono-boom and 2.0 m (6' 7"), 2.4 m (7' 10") & 2.92 m (9' 7") Arm.

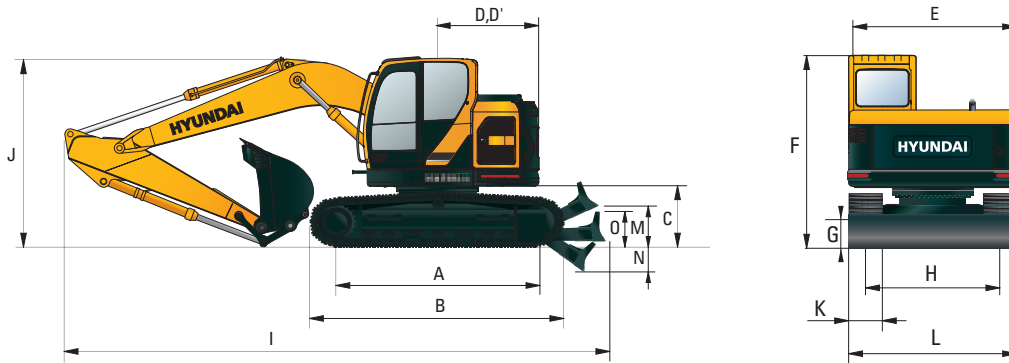

Unit : mm (ft-in)

A	Tumbler distance	3,650 (12' 0")
B	Overall length of crawler	4,404 (14' 6")
C	Ground clearance of counterweight	1,080 (3' 7")
D	Tail swing radius	1,780 (6' 04")
D'	Rear-end length	1,780 (6' 04")
E	Overall width of upperstructure	2,980 (9' 9")
F	Overall height of cab	3,290 (10' 10")
G	Min. ground clearance	480 (1' 7")
H	Track gauge	2,390 (7' 10")
M	Ground clearance of blade up	550 (1' 10")
N	Depth of blade down	410 (1' 4")
O	Height of blade	740 (2' 5")

Boom length	5,680 (18' 8")			
Arm length	2,000 (6' 7")	2,400 (7' 10")	2,920 (9' 7")	
I Overall length	10,020 (32' 10")	9,930 (32' 7")	9,890 (32' 5")	
J Overall height of boom	3,200 (10' 6")	3,100 (10' 2")	3,020 (9' 11")	
K Track shoe width	600 (24")	700 (28")	800 (32")	900 (36")
L Overall width	2,990 (9' 10")	3,090 (10' 2")	3,190 (10' 6")	3,290 (10' 10")

HX235 LCR (DOZER TYPE) WORKING RANGE

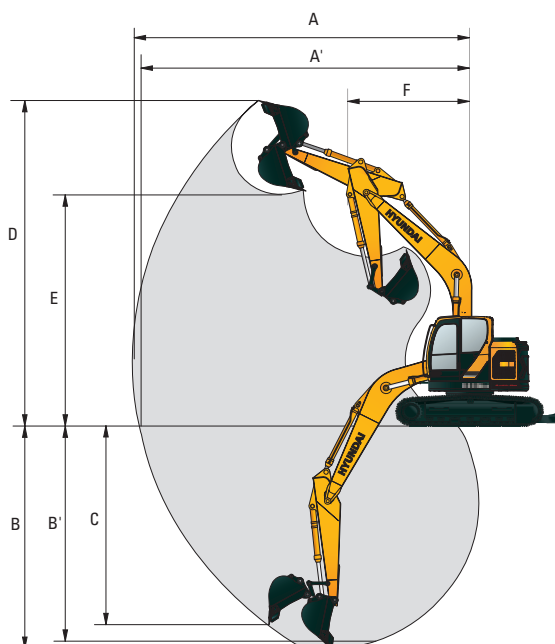

Unit : mm (ft-in)

Boom length	5,680 (18' 8")		
Arm length	2,000 (6' 7")	2,400 (7' 10")	2,920 (9' 7")
A Max. digging reach	9,040 (29' 8")	9,430 (30' 11")	9,910 (32' 6")
A' Max. digging reach on ground	8,860 (29' 1")	9,260 (30' 5")	9,750 (32' 0")
B Max. digging depth	5,780 (19' 0")	6,180 (20' 3")	6,700 (22' 0")
B' Max. digging depth (8' level)	5,550 (18' 3")	5,980 (19' 7")	6,530 (21' 5")
C Max. vertical wall digging depth	5,140 (16' 10")	5,710 (18' 9")	6,270 (20' 7")
D Max. digging height	10,090 (33' 1")	10,420 (34' 2")	10,830 (35' 6")
E Max. dumping height	7,190 (23' 7")	7,510 (24' 8")	7,890 (25' 11")
F Min. front swing radius	2,860 (9' 5")	2,550 (8' 4")	2,350 (7' 9")

DIMENSIONS & WORKING RANGE

HX235 LCR

HX235 LCR 2-PIECE BOOM DIMENSIONS

5.65 m (18' 6") 2-Piece Boom and 2.0 m (6' 7"), 2.4 m (7' 10") & 2.92 m (9' 7") Arm.

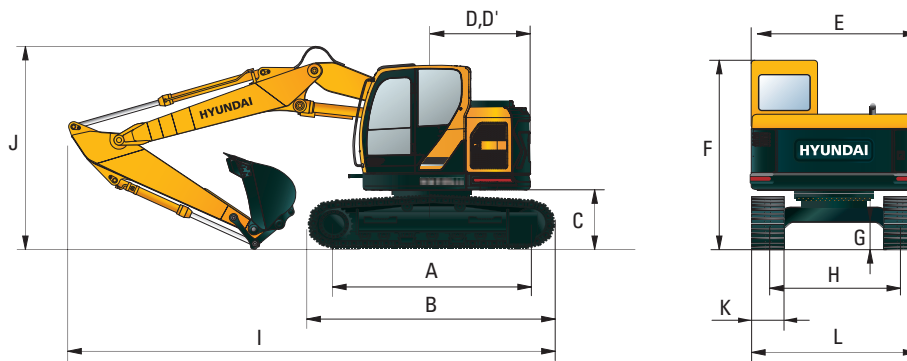

Unit : mm (ft-in)

A	Tumbler distance	3,650 (12' 0")
B	Overall length of crawler	4,404 (14' 6")
C	Ground clearance of counterweight	1,080 (3' 7")
D	Tail swing radius	1,780 (6' 04")
D'	Rear-end length	1,780 (6' 04")
E	Overall width of upperstructure	2,980 (9' 9")
F	Overall height of cab	3,290 (10' 10")
G	Min. ground clearance	480 (1' 7")
H	Track gauge	2,390 (7' 10")

Boom length	5,650 (18' 6") 2-Piece			
Arm length	2,000 (6' 7")	2,400 (7' 10")	2,920 (9' 7")	
I Overall length	9,000 (29' 6")	8,910 (29' 3")	8,900 (29' 2")	
J Overall height of boom	3,050 (10' 0")	3,000 (9' 10")	2,990 (9' 10")	
K Track shoe width	600 (24")	700 (28")	800 (32")	900 (36")
L Overall width	2,990 (9' 10")	3,090 (10' 2")	3,190 (10' 6")	3,290 (10' 10")

HX235 LCR 2-PIECE BOOM WORKING RANGE

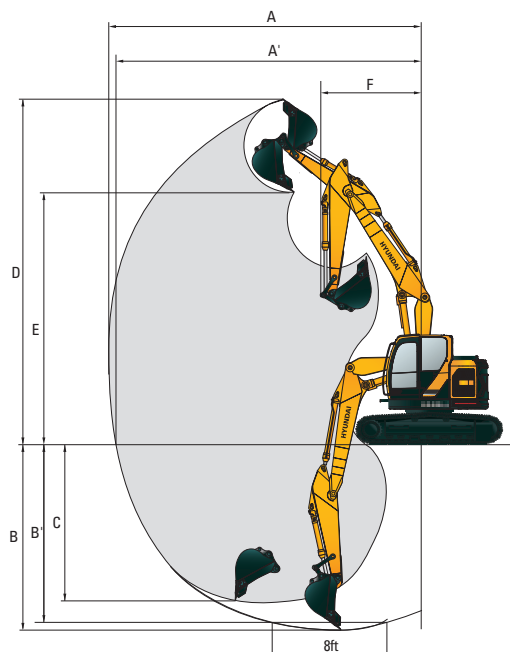

Unit : mm (ft-in)

Boom length	5,650 (18' 6") 2-Piece		
Arm length	2,000 (6' 7")	2,400 (7' 10")	2,920 (9' 7")
A Max. digging reach	9,050 (29' 8")	9,460 (31' 0")	10,020 (32' 10")
A' Max. digging reach on ground	8,880 (29' 2")	9,290 (30' 6")	9,860 (32' 4")
B Max. digging depth	5,460 (17' 11")	5,860 (19' 3")	6,380 (20' 11")
B' Max. digging depth (8° level)	5,340 (17' 6")	5,750 (18' 10")	6,270 (20' 7")
C Max. vertical wall digging depth	4,530 (14' 10")	4,970 (16' 4")	5,520 (18' 1")
D Max. digging height	10,600 (34' 9")	10,990 (36' 1")	11,470 (37' 8")
E Max. dumping height	7,680 (25' 2")	8,090 (26' 7")	8,540 (28' 0")
F Min. front swing radius	2,130 (7' 0")	2,030 (6' 8")	2,000 (6' 7")

DIMENSIONS & WORKING RANGE

HX235 LCR

HX235 LCR 2-PIECE BOOM (DOZER TYPE) DIMENSIONS

5.65 m (18' 6") 2-Piece Boom and 2.0 m (6' 7"), 2.4 m (7' 10") & 2.92 m (9' 7") Arm.

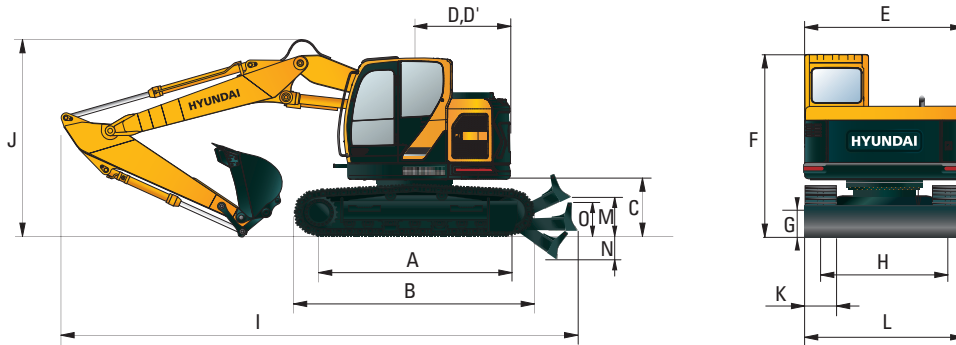

Unit : mm (ft-in)

A	Tumbler distance	3,650 (12' 0")
B	Overall length of crawler	4,404 (14' 6")
C	Ground clearance of counterweight	1,080 (3' 7")
D	Tail swing radius	1,780 (6' 04")
D'	Rear-end length	1,780 (6' 04")
E	Overall width of upperstructure	2,980 (9' 9")
F	Overall height of cab	3,290 (10' 10")
G	Min. ground clearance	480 (1' 7")
H	Track gauge	2,390 (7' 10")
M	Ground clearance of blade up	550 (1' 10")
N	Depth of blade down	410 (1' 4")
O	Height of blade	740 (2' 5")

Boom length	5,650 (18' 6") 2-Piece			
Arm length	2,000 (6' 7")	2,400 (7' 10")	2,920 (9' 7")	
I Overall length	9,850 (32' 4")	9,760 (32' 0")	9,750 (32' 0")	
J Overall height of boom	3,050 (10' 0")	3,000 (9' 10")	2,990 (9' 10")	
K Track shoe width	600 (24")	700 (28")	800 (32")	900 (36")
L Overall width	2,990 (9' 10")	3,090 (10' 2")	3,190 (10' 6")	3,290 (10' 10")

HX235 LCR 2-PIECE BOOM (DOZER TYPE) WORKING RANGE

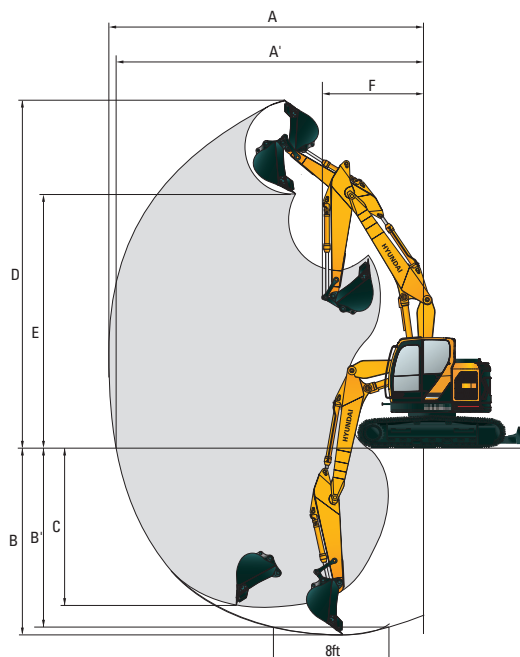

Unit : mm (ft-in)

Boom length	5,650 (18' 6") 2-Piece			
Arm length	2,000 (6' 7")	2,400 (7' 10")	2,920 (9' 7")	
A Max. digging reach	9,050 (29' 8")	9,460 (31' 0")	10,020 (32' 10")	
A' Max. digging reach on ground	8,880 (29' 2")	9,290 (30' 6")	9,860 (32' 4")	
B Max. digging depth	5,460 (17' 11")	5,860 (19' 3")	6,380 (20' 11")	
B' Max. digging depth (8' level)	5,340 (17' 6")	5,750 (18' 10")	6,270 (20' 7")	
C Max. vertical wall digging depth	4,530 (14' 10")	4,970 (16' 4")	5,520 (18' 1")	
D Max. digging height	10,600 (34' 9")	10,990 (36' 1")	11,470 (37' 8")	
E Max. dumping height	7,680 (25' 2")	8,090 (26' 7")	8,540 (28' 0")	
F Min. front swing radius	2,130 (7' 0")	2,030 (6' 8")	2,000 (6' 7")	











LIFTING CAPACITY

HX235 LCR











 Rating over-front  Rating over-side or 360 degrees

HX235 LCR MONO BOOM

Boom: 5.68 m (18' 8") / Arm: 2.0 m (6' 7") / Bucket: 0.80 m³ (1.05 yd³) SAE heaped / Shoe: 600 mm (24") triple grouser.

Load point height m (ft)	Load radius								At max. reach		
	3.0 m (10 ft)		4.5 m (15 ft)		6.0 m (20 ft)		7.5 m (25 ft)		Capacity	Reach	
											m (ft)
10.5 m (35 ft)	kg								*4160	*4160	4.63
	lb								*9170	*9170	(15.2)
9.0 m (30 ft)	kg								*4580	*4580	4.48
	lb								*10100	*10100	(14.7)
7.5 m (25 ft)	kg		*4770	*4770					*4100	*4100	6.56
	lb		*10520	*10520					*9040	*9040	(21.5)
6.0 m (20 ft)	kg		*4930	*4930	*4540	*4540			*3990	3080	7.70
	lb		*10870	*10870	*10010	*10010			*8800	6790	(25.3)
4.5 m (15 ft)	kg	*8300	*8300	*5880	*5880	*4860	4630		*3990	2580	8.36
	lb	*18300	*18300	*12960	*12960	*10710	10210		*8800	5690	(27.4)
3.0 m (10 ft)	kg		*7250	6860	*5440	4370	*4570	3000	*4030	2340	8.67
	lb		*15980	15120	*11990	9630	*10080	6610	*8880	5160	(28.4)
1.5 m (5 ft)	kg		*8350	6350	*5980	4120	*4770	2890	*4080	2290	8.66
	lb		*18410	14000	*13180	9080	*10520	6370	*8990	5050	(28.4)
Ground Line	kg		*8660	6110	*6250	3960			*4100	2410	8.36
	lb		*19090	13470	*13780	8730			*9040	5310	(27.4)
-1.5 m (-5 ft)	kg	*11410	*11410	*8260	6080	*6050	3910		*4010	2790	7.69
	lb	*25150	*25150	*18210	13400	*13340	8620		*8840	6150	(25.2)
-3.0 m (-10 ft)	kg	*9650	*9650	*7130	6190	*5090	4000		*3610	*3610	6.55
	lb	*21270	*21270	*15720	13650	*11220	8820		*7960	*7960	(21.5)

Boom: 5.68 m (18' 8") / Arm: 2.4 m (7' 10") / Bucket: 0.80 m³ (1.05 yd³) SAE heaped / Shoe: 600 mm (24") triple grouser.

Load point height m (ft)	Load radius								At max. reach				
	1.5 m (5 ft)		3.0 m (10 ft)		4.5 m (15 ft)		6.0 m (20 ft)		7.5 m (25 ft)		Capacity	Reach	
											m (ft)		
9.0 m (30 ft)	kg										*4060	*4060	5.25
	lb										*8950	*8950	(17.2)
7.5 m (25 ft)	kg				*4230	*4230					*3770	3710	7.07
	lb				*9330	*9330					*8310	8180	(23.2)
6.0 m (20 ft)	kg				*4450	*4450	*4170	*4170			*3700	2800	8.12
	lb				*9810	*9810	*9190	*9190			*8160	6170	(26.6)
4.5 m (15 ft)	kg		*7210	*7210	*5400	*5400	*4550	*4550	*3900	3120	*3720	2370	8.74
	lb		*15900	*15900	*11900	*11900	*10030	*10030	*8600	6880	*8200	5220	(28.7)
3.0 m (10 ft)	kg		*11320	*11320	*6790	*6790	*5170	4410	*4360	3010	*3770	2160	9.04
	lb		*24960	*24960	*14970	*14970	*11400	9720	*9610	6640	*8310	4760	(29.7)
1.5 m (5 ft)	kg				*8040	6400	*5790	4130	*4630	2880	*3830	2110	9.03
	lb				*17730	14110	*12760	9110	*10210	6350	*8440	4650	(29.6)
Ground Line	kg		*9170	*9170	*8580	6100	*6150	3940	*4760	2780	*3870	2210	8.74
	lb		*20220	*20220	*18920	13450	*13560	8690	*10490	6130	*8530	4870	(28.7)
-1.5 m (-5 ft)	kg	*9770	*9770	*12150	12070	*8390	6010	*6100	3860		*3840	2510	8.12
	lb	*21540	*21540	*26790	26610	*18500	13250	*13450	8510		*8470	5530	(26.6)
-3.0 m (-10 ft)	kg	*14230	*14230	*10480	*10480	*7490	6080	*5420	3900		*3600	3230	7.06
	lb	*31370	*31370	*23100	*23100	*16510	13400	*11950	8600		*7940	7120	(23.2)
-4.5 m (-15 ft)	kg		*7610	*7610	*5470	*5470							
	lb		*16780	*16780	*12060	*12060							

1. Lifting capacity are based on SAE J1097 and ISO 10567.

2. Lifting capacity of the ROBEX series does not exceed 75% of tipping load with the machine on firm, level ground or 87% of full hydraulic capacity.

3. The load point is a hook (standard equipment) located on the back of the bucket.

4. (*) indicates load limited by hydraulic capacity.













LIFTING CAPACITY

HX235 LCR











 Rating over-front  Rating over-side or 360 degrees

HX235 LCR MONO BOOM

Boom: 5.68 m (18' 8") / Arm: 2.92 m (9' 7") / Bucket: 0.80 m³ (1.05 yd³) SAE heaped / Shoe: 600 mm (24") triple grouser.

Load point height m (ft)	Load radius										At max. reach			
	1.5 m (5 ft)		3.0 m (10 ft)		4.5 m (15 ft)		6.0 m (20 ft)		7.5 m (25 ft)		Capacity		Reach m (ft)	
														
9.0 m (30 ft)	kg				*2920	*2920					*3570	*3570	6.12	
	lb				*6440	*6440					*7870	*7870	(20.1)	
7.5 m (25 ft)	kg						*3260	*3260			*3410	3210	7.70	
	lb						*7190	*7190			*7520	7080	(25.3)	
6.0 m (20 ft)	kg						*3720	*3720			*3380	2500	8.66	
	lb						*8200	*8200			*7450	5510	(28.4)	
4.5 m (15 ft)	kg				*4750	*4750	*4140	*4140	*3800	3170	*3410	2130	9.24	
	lb				*10470	*10470	*9130	*9130	*8380	6990	*7520	4700	(30.3)	
3.0 m (10 ft)	kg		*9680	*9680	*6180	*6180	*4810	4460	*4100	3030	*3460	1950	9.52	
	lb		*21340	*21340	*13620	*13620	*10600	9830	*9040	6680	*7630	4300	(31.2)	
1.5 m (5 ft)	kg		*9550	*9550	*7590	6510	*5500	4160	*4440	2880	*3530	1900	9.52	
	lb		*21050	*21050	*16730	14350	*12130	9170	*9790	6350	*7780	4190	(31.2)	
Ground Line	kg		*9930	*9930	*8400	6110	*5990	3930	*4670	2760	*3600	1970	9.24	
	lb		*21890	*21890	*18520	13470	*13210	8660	*10300	6080	*7940	4340	(30.3)	
-1.5 m (-5 ft)	kg	*8850	*8850	*12790	11890	*8470	5950	*6100	3810	*4630	2690	*3620	2210	8.66
	lb	*19510	*19510	*28200	26210	*18670	13120	*13450	8400	10210	5930	*7980	4870	(28.4)
-3.0 m (-10 ft)	kg	*12280	*12280	*11380	*11380	*7840	5960	*5690	3810			*3500	2750	7.69
	lb	*27070	*27070	*25090	*25090	*17280	13140	*12540	8400			*7720	6060	(25.2)
-4.5 m (-15 ft)	kg			*8920	*8920	*6300	6140					*2930	*2930	6.11
	lb			*19670	*19670	*13890	13540					*6460	*6460	(20.0)

Boom: 5.68 m (18' 8") / Arm: 2.0 m (7' 10") / Bucket: 0.80 m³ (1.05 yd³) SAE heaped / Shoe: 600 mm (24") triple grouser. Dozer Blade up

Load point height m (ft)	Load radius								At max. reach			
	3.0 m (10 ft)		4.5 m (15 ft)		6.0 m (20 ft)		7.5 m (25 ft)		Capacity		Reach m (ft)	
												
10.5 m (35 ft)	kg									*4160	*4160	4.63
	lb									*9170	*9170	(15.2)
9.0 m (30 ft)	kg									*4580	*4580	4.48
	lb									*10100	*10100	(14.7)
7.5 m (25 ft)	kg			*4770	*4770					*4100	*4100	6.56
	lb			*10520	*10520					*9040	*9040	(21.5)
6.0 m (20 ft)	kg			*4930	*4930	*4540	*4540			*3990	3520	7.70
	lb			*10870	*10870	*10010	*10010			*8800	7760	(25.3)
4.5 m (15 ft)	kg	*8300	*8300	*5880	*5880	*4860	*4860			*3990	2960	8.36
	lb	*18300	*18300	*12960	*12960	*10710	*10710			*8800	6530	(27.4)
3.0 m (10 ft)	kg			*7250	*7250	*5440	4980	*4570	3440	*4030	2710	8.67
	lb			*15980	*15980	*11990	10980	*10080	7580	*8880	5970	(28.4)
1.5 m (5 ft)	kg			*8350	7280	*5980	4730	*4770	3330	*4080	2660	8.66
	lb			*18410	16050	*13180	10430	*10520	7340	*8990	5860	(28.4)
Ground Line	kg			*8660	7040	*6250	4560			*4100	2800	8.36
	lb			*19090	15520	*13780	10050			*9040	6170	(27.4)
-1.5 m (-5 ft)	kg	*11410	*11410	*8260	7010	*6050	4510			*4010	3220	7.69
	lb	*25150	*25150	*18210	15450	*13340	9940			*8840	7100	(25.2)
-3.0 m (-10 ft)	kg	*9650	*9650	*7130	7130	*5090	4610			*3610	*3610	6.55
	lb	*21270	*21270	*15720	15720	*11220	10160			*7960	*7960	(21.5)

1. Lifting capacity are based on SAE J1097 and ISO 10567.

2. Lifting capacity of the ROBEX series does not exceed 75% of tipping load with the machine on firm, level ground or 87% of full hydraulic capacity.

3. The load point is a hook (standard equipment) located on the back of the bucket.

4. (*) indicates load limited by hydraulic capacity.











LIFTING CAPACITY

HX235 LCR













 Rating over-front  Rating over-side or 360 degrees

HX235 LCR MONO BOOM

Boom: 5.68 m (18' 8") / Arm: 2.0 m (6' 7") / Bucket: 0.80 m³ (1.05 yd³) SAE heaped / Shoe: 600 mm (24") triple grouser. Dozer Blade down

Load point height m (ft)	Load radius								At max. reach			
	3.0 m (10 ft)		4.5 m (15 ft)		6.0 m (20 ft)		7.5 m (25 ft)		Capacity		Reach m (ft)	
												
10.5 m (35 ft)	kg									*4160	*4160	4.63
	lb									*9170	*9170	(15.2)
9.0 m (30 ft)	kg									*4580	*4580	4.48
	lb									*10100	*10100	(14.7)
7.5 m (25 ft)	kg		*4770	*4770						*4100	*4100	6.56
	lb		*10520	*10520						*9040	*9040	(21.5)
6.0 m (20 ft)	kg		*4930	*4930	*4540	*4540				*3990	3300	7.70
	lb		*10870	*10870	*10010	*10010				*8800	7280	(25.3)
4.5 m (15 ft)	kg	*8300	*8300	*5880	*5880	*4860	*4860			*3990	2770	8.36
	lb	*18300	*18300	*12960	*12960	*10710	*10710			*8800	6110	(27.4)
3.0 m (10 ft)	kg		*7250	*7250	*5440	4660	*4570	3220		*4030	2530	8.67
	lb		*15980	*15980	*11990	10270	*10080	7100		*8880	5580	(28.4)
1.5 m (5 ft)	kg		*8350	6770	*5980	4410	*4770	3110		*4080	2480	8.66
	lb		*18410	14930	*13180	9720	*10520	6860		*8990	5470	(28.4)
Ground Line	kg		*8660	6530	*6250	4250				*4100	2610	8.36
	lb		*19090	14400	*13780	9370				*9040	5750	(27.4)
-1.5 m (-5 ft)	kg	*11410	*11410	*8260	6500	*6050	4200			*4010	3000	7.69
	lb	*25150	*25150	*18210	14330	*13340	9260			*8840	6610	(25.2)
-3.0 m (-10 ft)	kg	*9650	*9650	*7130	6610	*5090	4290			*3610	*3610	6.55
	lb	*21270	*21270	*15720	14570	*11220	9460			*7960	*7960	(21.5)

Boom: 5.68 m (18' 8") / Arm: 2.4 m (7' 10") / Bucket: 0.80 m³ (1.05 yd³) SAE heaped / Shoe: 600 mm (24") triple grouser. Dozer Blade up

Load point height m (ft)	Load radius								At max. reach				
	1.5 m (5 ft)		3.0 m (10 ft)		4.5 m (15 ft)		6.0 m (20 ft)		7.5 m (25 ft)		Capacity		Reach m (ft)
													
9.0 m (30 ft)	kg										*4060	*4060	5.25
	lb										*8950	*8950	(17.2)
7.5 m (25 ft)	kg				*4230	*4230					*3770	*3770	7.07
	lb				*9330	*9330					*8310	*8310	(23.2)
6.0 m (20 ft)	kg				*4450	*4450	*4170	*4170			*3700	3210	8.12
	lb				*9810	*9810	*9190	*9190			*8160	7080	(26.6)
4.5 m (15 ft)	kg		*7210	*7210	*5400	*5400	*4550	*4550	*3900	3560	*3720	2730	8.74
	lb		*15900	*15900	*11900	*11900	*10030	*10030	*8600	7850	*8200	6020	(28.7)
3.0 m (10 ft)	kg		*11320	*11320	*6790	*6790	*5170	5020	*4360	3450	*3770	2510	9.04
	lb		*24960	*24960	*14970	*14970	*11400	11070	*9610	7610	*8310	5530	(29.7)
1.5 m (5 ft)	kg				*8040	7340	*5790	4740	*4630	3320	*3830	2460	9.03
	lb				*17730	16180	*12760	10450	*10210	7320	*8440	5420	(29.6)
Ground Line	kg		*9170	*9170	*8580	7030	*6150	4540	*4760	3230	*3870	2570	8.74
	lb		*20220	*20220	*18920	15500	*13560	10010	*10490	7120	*8530	5670	(28.7)
-1.5 m (-5 ft)	kg	*9770	*9770	*12150	*12150	*8390	6940	*6100	4460		*3840	2920	8.12
	lb	*21450	*21450	*26790	*26790	*18500	15300	*13450	9830		*8470	6440	(26.6)
-3.0 m (-10 ft)	kg	*14230	*14230	*10480	*10480	*7490	7020	*5420	4510		*3600	*3600	7.06
	lb	*31370	*31370	*23100	*23100	*16510	15480	*11950	9940		*7940	*7940	(23.2)
-4.5 m (-15 ft)	kg		*7610	*7610	*5470	*5470							
	lb		*16780	*16780	*12060	*12060							

1. Lifting capacity are based on SAE J1097 and ISO 10567.

2. Lifting capacity of the ROBEX series does not exceed 75% of tipping load with the machine on firm, level ground or 87% of full hydraulic capacity.

3. The load point is a hook (standard equipment) located on the back of the bucket.

4. (*) indicates load limited by hydraulic capacity.













LIFTING CAPACITY

HX235 LCR













 Rating over-front  Rating over-side or 360 degrees

HX235 LCR MONO BOOM

Boom: 5.68 m (18' 8") / Arm: 2.4 m (7' 10") / Bucket: 0.80 m³ (1.05 yd³) SAE heaped / Shoe: 600 mm (24") triple grouser. Dozer Blade down

Load point height m (ft)	Load radius										At max. reach			
	1.5 m (5 ft)		3.0 m (10 ft)		4.5 m (15 ft)		6.0 m (20 ft)		7.5 m (25 ft)		Capacity		Reach m (ft)	
														
9.0 m (30 ft)	kg											*4060	*4060	5.25
	lb											*8950	*8950	(17.2)
7.5 m (25 ft)	kg				*4230	*4230						*3770	*3770	7.07
	lb				*9330	*9330						*8310	*8310	(23.2)
6.0 m (20 ft)	kg				*4450	*4450	*4170	*4170				*3700	3000	8.12
	lb				*9810	*9810	*9190	*9190				*8160	6610	(26.6)
4.5 m (15 ft)	kg		*7210	*7210	*5400	*5400	*4550	*4550	*3900	3340		*3720	2550	8.74
	lb		*15900	*15900	*11900	*11900	*10030	*10030	*8600	7360		*8200	5620	(28.7)
3.0 m (10 ft)	kg		*11320	*11320	*6790	*6790	*5170	4700	*4360	3230		*3770	2340	9.04
	lb		*24960	*24960	*14970	*14970	*11400	10360	*9610	7120		*8310	5160	(29.7)
1.5 m (5 ft)	kg				*8040	6830	*5790	4420	*4630	3100		*3830	2280	9.03
	lb				*17730	15060	*12760	9740	*10210	6830		*8440	5030	(29.6)
Ground Line	kg		*9170	*9170	*8580	6520	*6150	4230	*4760	3000		*3870	2390	8.74
	lb		*20220	*20220	*18920	14370	*13560	9330	*10490	6610		*8530	5270	(28.7)
-1.5 m (-5 ft)	kg	*9770	*9770	*12150	12070	*8390	6440	*6100	4150			*3840	2710	8.12
	lb	*21540	*21540	*26790	26610	*18500	14200	*13450	9150			*8470	5970	(26.6)
-3.0 m (-10 ft)	kg	*14230	*14230	*10480	*10480	*7490	6510	*5420	4190			*3600	3470	7.06
	lb	*31370	*31370	*23100	*23100	*16510	14350	*11950	9240			*7940	7650	(23.2)
-4.5 m (-15 ft)	kg		*7610	*7610	*5470	*5470								
	lb		*16780	*16780	*12060	*12060								

Boom: 5.68 m (18' 8") / Arm: 2.92 m (9' 7") / Bucket: 0.80 m³ (1.05 yd³) SAE heaped / Shoe: 600 mm (24") triple grouser. Dozer Blade up

Load point height m (ft)	Load radius										At max. reach			
	1.5 m (5 ft)		3.0 m (10 ft)		4.5 m (15 ft)		6.0 m (20 ft)		7.5 m (25 ft)		Capacity		Reach m (ft)	
														
9.0 m (30 ft)	kg					*2920	*2920					*3570	*3570	6.12
	lb					*6440	*6440					*7870	*7870	(20.1)
7.5 m (25 ft)	kg							*3260	*3260			*3410	*3410	7.70
	lb							*7190	*7190			*7520	*7520	(25.3)
6.0 m (20 ft)	kg							*3720	*3720			*3380	2870	8.66
	lb							*8200	*8200			*7450	6330	(28.4)
4.5 m (15 ft)	kg					*4750	*4750	*4140	*4140	*3800	3620	*3410	2470	9.24
	lb					*10470	*10470	*9130	*9130	*8380	7980	*7520	5450	(30.3)
3.0 m (10 ft)	kg		*9680	*9680	*6180	*6180	*4810	*4810	*4100	3480		*3460	2280	9.52
	lb		*21340	*21340	*13620	*13620	*10600	*10600	*9040	7670		*7630	5030	(31.2)
1.5 m (5 ft)	kg		*9550	*9550	*7590	7450	*5500	4770	*4440	3330		*3530	2230	9.52
	lb		*21050	*21050	*16730	16420	*12130	10520	*9790	7340		*7780	4920	(31.2)
Ground Line	kg		*9930	*9930	*8400	7040	*5990	4530	*4670	3200		*3600	2310	9.24
	lb		*21890	*21890	*18520	15520	*13210	9990	*10300	7050		*7940	5090	(30.3)
-1.5 m (-5 ft)	kg	*8850	*8850	*12790	11890	*8470	6880	*6100	4410	*4630	3140	*3620	2580	8.66
	lb	*19510	*19510	*28200	26210	*18670	15170	*13450	9720	*10210	6920	*7980	5690	(28.4)
-3.0 m (-10 ft)	kg	*12280	*12280	*11380	*11380	*7840	6900	*5690	4410			*3500	3180	7.69
	lb	*27070	*27070	*25090	*25090	*17280	15210	*12540	9720			*7720	7010	(25.2)
-4.5 m (-15 ft)	kg		*8920	*8920	*6300	*6300						*2930	*2930	6.11
	lb		*19670	*19670	*13890	*13890						*6460	*6460	(20.0)

1. Lifting capacity are based on SAE J1097 and ISO 10567.

2. Lifting capacity of the ROBEX series does not exceed 75% of tipping load with the machine on firm, level ground or 87% of full hydraulic capacity.

3. The load point is a hook (standard equipment) located on the back of the bucket.

4. (*) indicates load limited by hydraulic capacity.













LIFTING CAPACITY

HX235 LCR

 Rating over-front  Rating over-side or 360 degrees











HX235 LCR MONO BOOM

Boom: 5.68 m (18' 8") / Arm: 2.92 m (9' 7") / Bucket: 0.80 m³ (1.05 yd³) SAE heaped / Shoe: 600 mm (24") triple grouser. Dozer Blade down

Load point height m (ft)	Load radius										At max. reach			
	1.5 m (5 ft)		3.0 m (10 ft)		4.5 m (15 ft)		6.0 m (20 ft)		7.5 m (25 ft)		Capacity		Reach m (ft)	
														
9.0 m (30 ft)	kg				*2920	*2920					*3570	*3570	6.12	
	lb				*6440	*6440					*7870	*7870	(20.1)	
7.5 m (25 ft)	kg						*3260	*3260			*3410	*3410	7.70	
	lb						*7190	*7190			*7520	*7520	(25.3)	
6.0 m (20 ft)	kg						*3720	*3720			*3380	2680	8.66	
	lb						*8200	*8200			*7450	5910	(28.4)	
4.5 m (15 ft)	kg				*4750	*4750	*4140	*4140	*3800	3390	*3410	2300	9.24	
	lb				*10470	*10470	*9130	*9130	*8380	7470	*7520	5070	(30.3)	
3.0 m (10 ft)	kg		*9680	*9680	*6180	*6180	*4810	4750	*4100	3250	*3460	2120	9.52	
	lb		*21340	*21340	*13620	*13620	*10600	10470	*9040	7170	*7630	4670	(31.2)	
1.5 m (5 ft)	kg		*9550	*9550	*7590	6930	*5500	4450	*4440	3100	*3530	2070	9.52	
	lb		*21050	*21050	*16730	15280	*12130	9810	*9790	6830	*7780	4560	(31.2)	
Ground Line	kg		*9930	*9930	*8400	6530	*5990	4220	*4670	2980	*3600	2150	9.24	
	lb		*21890	*21890	*18520	14400	*13210	9300	*10300	6570	*7940	4740	(30.3)	
-1.5 m (-5 ft)	kg	*8850	*8850	*12790	12690	*8470	6370	*6100	4100	*4630	2910	*3620	2400	8.66
	lb	*19510	*19510	*28200	27980	*18670	14040	*13450	9040	*10210	6420	*7980	5290	(28.4)
-3.0 m (-10 ft)	kg	*12280	*12280	*11380	*11380	*7840	6390	*5690	4100			*3500	2960	7.69
	lb	*27070	*27070	*25090	*25090	*17280	14090	*12540	9040			*7720	6530	(25.2)
-4.5 m (-15 ft)	kg			*8920	*8920	*6300	*6300					*2930	*2930	6.11
	lb			*19670	*19670	*13890	*13890					*6460	*6460	(20.0)

HX235 LCR 2-PIECE BOOM

Boom: 5.65 m (18' 6") / Arm: 2.0 m (6' 7") / Bucket: 0.80 m³ (1.05 yd³) SAE heaped / Shoe: 600 mm (24") triple grouser. Dozer Blade up

Load point height m (ft)	Load radius										At max. reach		
	3.0 m (10 ft)		4.5 m (15 ft)		6.0 m (20 ft)		7.5 m (25 ft)		Capacity		Reach m (ft)		
													
9.0 m (30 ft)	kg										*6750	*6750	4.51
	lb										*14880	*14880	(14.8)
7.5 m (25 ft)	kg	*8110	*8110	*6850	*6850						*5200	4700	6.58
	lb	*17880	*17880	*15100	*15100						*11460	10360	(21.6)
6.0 m (20 ft)	kg	*8460	*8460	*6960	*6960	*5740	5390				*4630	3470	7.72
	lb	*18650	*18650	*15340	*15340	*12650	11880				*10210	7650	(25.3)
4.5 m (15 ft)	kg	*11210	*11210	*7620	*7620	*5920	5230				*4270	2920	8.37
	lb	*24710	*24710	*16800	*16800	*13050	11530				*9410	6440	(27.5)
3.0 m (10 ft)	kg			*8430	7790	*6190	4950	*4850	3410		*3960	2670	8.68
	lb			*18580	17170	*13650	10910	*10690	7520		*8730	5890	(28.5)
1.5 m (5 ft)	kg			*8660	7230	*6260	4690	*4710	3300		*3610	2620	8.68
	lb			*19090	15940	*13800	10340	*10380	7280		*7960	5780	(28.5)
Ground Line	kg			*7950	6980	*5880	4520	*4200	3230		*3130	2770	8.37
	lb			*17530	15390	*12960	9960	*9260	7120		*6900	6110	(27.5)
-1.5 m (-5 ft)	kg	*7060	*7060	*6470	*6470	*4870	4480				*2330	*2330	7.71
	lb	*15560	*15560	*14260	*14260	*10740	9880				*5140	*5140	(25.3)
-3.0 m (-10 ft)	kg			*4140	*4140	*2800	*2800						
	lb			*9130	*9130	*6170	*6170						

1. Lifting capacity are based on SAE J1097 and ISO 10567.

2. Lifting capacity of the ROBEX series does not exceed 75% of tipping load with the machine on firm, level ground or 87% of full hydraulic capacity.

3. The load point is a hook (standard equipment) located on the back of the bucket.

4. (*) indicates load limited by hydraulic capacity.











LIFTING CAPACITY

HX235 LCR











 Rating over-front  Rating over-side or 360 degrees

HX235 LCR 2-PIECE BOOM

Boom: 5.65 m (18' 6") / Arm: 2.0 m (6' 7") / Bucket: 0.80 m³ (1.05 yd³) SAE heaped / Shoe: 600 mm (24") triple grouser. Dozer Blade down

Load point height m (ft)	Load radius								At max. reach			
	3.0 m (10 ft)		4.5 m (15 ft)		6.0 m (20 ft)		7.5 m (25 ft)		Capacity		Reach m (ft)	
												
9.0 m (30 ft)	kg								*6750	*6750	4.51	
	lb								*14880	*14880	(14.8)	
7.5 m (25 ft)	kg	*8110	*8110	*6850	*6850				*5200	4420	6.58	
	lb	*17880	*17880	*15100	*15100				*11460	9740	(21.6)	
6.0 m (20 ft)	kg	*8460	*8460	*6960	*6960	*5740	5060		*4630	3250	7.72	
	lb	*18650	*18650	*15340	*15340	*12650	11160		*10210	7170	(25.3)	
4.5 m (15 ft)	kg	*11210	*11210	*7620	*7620	*5920	4900		*4270	2720	8.37	
	lb	*24710	*24710	*16800	*16800	*13050	10800		*9410	6000	(27.5)	
3.0 m (10 ft)	kg			*8430	7250	*6190	4630	*4850	3180	*3960	2480	8.68
	lb			*18580	15980	*13650	10210	*10690	7010	*8730	5470	(28.5)
1.5 m (5 ft)	kg			*8660	6710	*6260	4370	*4710	3070	*3610	2440	8.68
	lb			*19090	14790	*13800	9630	*10380	6770	7960	5380	(28.5)
Ground Line	kg			*7950	6460	*5880	4200	*4200	3000	*3130	2580	8.37
	lb			*17530	14240	*12960	9260	*9260	6610	*6900	5690	(27.5)
-1.5 m (-5 ft)	kg	*7060	*7060	*6470	6450	*4870	4160		*2330	*2330	7.71	
	lb	*15560	*15560	*14260	14220	*10740	9170		*5140	*5140	(25.3)	
-3.0 m (-10 ft)	kg			*4140	*4140	*2800	*2800					
	lb			*9130	*9130	*6170	*6170					

Boom: 5.65 m (18' 6") / Arm: 2.4 m (7' 10") / Bucket: 0.80 m³ (1.05 yd³) SAE heaped / Shoe: 600 mm (24") triple grouser. Dozer Blade up

Load point height m (ft)	Load radius								At max. reach			
	3.0 m (10 ft)		4.5 m (15 ft)		6.0 m (20 ft)		7.5 m (25 ft)		Capacity		Reach m (ft)	
												
9.0 m (30 ft)	kg	*5600	*5600						*5830	*5830	5.31	
	lb	*12350	*12350						*12850	*12850	(17.4)	
7.5 m (25 ft)	kg	*6240	*6240	*5830	*5830				*4760	4140	7.10	
	lb	*13760	*13760	*12850	*12850				*10490	9130	(23.3)	
6.0 m (20 ft)	kg	*6390	*6390	*6570	*6570	*5480	5480		*4290	3150	8.15	
	lb	*14090	*14090	*14480	*14480	*12080	12080		*9460	6940	(26.7)	
4.5 m (15 ft)	kg	*10370	*10370	*7270	*7270	*5720	5290	*4040	3540	*3980	2690	8.77
	lb	*22860	*22860	*16030	*16030	*12610	11660	*8910	7800	*8770	5930	(28.8)
3.0 m (10 ft)	kg			*8170	7920	*6050	5000	*4790	3430	*3720	2470	9.06
	lb			*18010	17460	*13340	11020	*10560	7560	*8200	5450	(29.7)
1.5 m (5 ft)	kg			*8620	7300	*6220	4700	*4740	3290	*3420	2420	9.06
	lb			*19000	16090	*13710	10360	*10450	7250	*7540	5340	(29.7)
Ground Line	kg	*8940	*8940	*8190	6970	*5980	4500	*4400	3190	*3010	2540	8.77
	lb	*19710	*19710	*18060	15370	*13180	9920	*9700	7030	*6640	5600	(28.8)
-1.5 m (-5 ft)	kg	*8500	*8500	*6940	6890	*5160	4430		*2360	*2360	8.15	
	lb	*18740	*18740	*15300	15190	*11380	9770		*5200	*5200	(26.7)	
-3.0 m (-10 ft)	kg			*4860	*4860	*3490	*3490					
	lb			*10710	*10710	*7690	*7690					

1. Lifting capacity are based on SAE J1097 and ISO 10567.

2. Lifting capacity of the ROBEX series does not exceed 75% of tipping load with the machine on firm, level ground or 87% of full hydraulic capacity.

3. The load point is a hook (standard equipment) located on the back of the bucket.

4. (*) indicates load limited by hydraulic capacity.











LIFTING CAPACITY

HX235 LCR











 Rating over-front  Rating over-side or 360 degrees

HX235 LCR

Boom: 5.65 m (18' 6") / Arm: 2.4 m (7' 10") / Bucket: 0.80 m³ (1.05 yd³) SAE heaped / Shoe: 600 mm (24") triple grouser. Dozer Blade down

Load point height m (ft)	Load radius								At max. reach		
	3.0 m (10 ft)		4.5 m (15 ft)		6.0 m (20 ft)		7.5 m (25 ft)		Capacity		Reach m (ft)
											
9.0 m (30 ft)	kg *5600	kg *5600							kg *5830	kg *5830	5.31 (17.4)
	lb *12350	lb *12350							kg *12850	kg *12850	
7.5 m (25 ft)	kg *6240	kg *6240	kg *5830	kg *5830					kg *4760	kg 3880	7.10 (23.3)
	lb *13760	lb *13760	kg *12850	kg *12850					kg *10490	kg 8550	
6.0 m (20 ft)	kg *6390	kg *6390	kg *6570	kg *6570	kg *5480	5140			kg *4290	kg 2950	8.15 (26.7)
	lb *14090	lb *14090	kg *14480	kg *14480	kg *12080	11330			kg *9460	kg 6500	
4.5 m (15 ft)	kg *10370	kg *10370	kg *7270	kg *7270	kg *5720	4960	kg *4040	3310	kg *3980	kg 2500	8.77 (28.8)
	lb *22860	lb *22860	kg *16030	kg *16030	kg *12610	10930	kg *8910	7300	kg *8770	kg 5510	
3.0 m (10 ft)	kg	kg	kg *8170	kg 7380	kg *6050	4670	kg *4790	3200	kg *3720	kg 2290	9.06 (29.7)
	lb	lb	kg *18010	kg 16270	kg *13340	10300	kg *10560	7050	kg *8200	kg 5050	
1.5 m (5 ft)	kg	kg	kg *8620	kg 6770	kg *6220	4380	kg *4740	3060	kg *3420	kg 2240	9.06 (29.7)
	lb	lb	kg *19000	kg 14930	kg *13710	9660	kg *10450	6750	kg *7540	kg 4940	
Ground Line	kg *8940	kg *8940	kg *8190	kg 6450	kg *5980	4180	kg *4400	2960	kg *3010	kg 2350	8.77 (28.8)
	lb *19710	lb *19710	kg *18060	kg 14220	kg *13180	9220	kg *9700	6530	kg *6640	kg 5180	
-1.5 m (-5 ft)	kg *8500	kg *8500	kg *6940	kg 6370	kg *5160	4110			kg *2360	kg *2360	8.15 (26.7)
	lb *18740	lb *18740	kg *15300	kg 14040	kg *11380	9060			kg *5200	kg *5200	
-3.0 m (-10 ft)	kg	kg	kg *4860	kg *4860	kg *3490	*3490					
	lb	lb	kg *10710	kg *10710	kg *7690	*7690					

Boom: 5.65 m (18' 6") / Arm: 2.92 m (9' 7") / Bucket: 0.80 m³ (1.05 yd³) SAE heaped / Shoe: 600 mm (24") triple grouser. Dozer Blade up

Load point height m (ft)	Load radius								At max. reach		
	3.0 m (10 ft)		4.5 m (15 ft)		6.0 m (20 ft)		7.5 m (25 ft)		Capacity		Reach m (ft)
											
9.0 m (30 ft)	kg *4950	kg *4950	kg *3120	kg *3120					kg *4630	kg *4630	6.19 (20.3)
	lb *10910	lb *10910	kg *6880	kg *6880					kg *10210	kg *10210	
7.5 m (25 ft)	kg	kg	kg *4750	kg *4750	kg *3400	*3400			kg *4050	kg 3560	7.75 (25.4)
	lb	lb	kg *10470	kg *10470	kg *7500	*7500			kg *8930	kg 7850	
6.0 m (20 ft)	kg *4760	kg *4760	kg *5190	kg *5190	kg *4840	*4840	kg *2180	*2180	kg *3820	kg 2800	8.71 (28.6)
	lb	lb	kg *11440	kg *11440	kg *10670	*10670	kg *4810	*4810	kg *8420	kg 6170	
4.5 m (15 ft)	kg *6690	kg *6690	kg *6760	kg *6760	kg *5420	5370	kg *4250	3600	kg *3650	kg 2410	9.29 (30.5)
	lb	lb	kg *14750	kg *14750	kg *14900	*14900	kg *9370	7640	kg *8050	kg 5310	
3.0 m (10 ft)	kg *12100	kg *12100	kg *7760	kg *7760	kg *5820	5060	kg *4670	3450	kg *3430	kg 2220	9.56 (31.4)
	lb	lb	kg *26680	kg *26680	kg *17110	*17110	kg *12830	11160	kg *10300	kg 7610	
1.5 m (5 ft)	kg *9380	kg *9380	kg *8470	kg 7400	kg *6110	4730	kg *4710	3290	kg *3180	kg 2180	9.56 (31.4)
	lb	lb	kg *20680	kg *20680	kg *18670	16310	kg *13470	10430	kg *10380	kg 7250	
Ground Line	kg *9730	kg *9730	kg *8370	kg 6970	kg *6040	4480	kg *4520	3160	kg *2850	kg 2270	9.29 (30.5)
	lb	lb	kg *21450	kg *21450	kg *18450	15370	kg *13320	9880	kg *9960	kg 6970	
-1.5 m (-5 ft)	kg *9980	kg *9980	kg *7420	kg 6810	kg *5440	4360	kg *3890	3100	kg *2330	kg *2330	8.71 (28.6)
	lb	lb	kg *22000	kg *22000	kg *16360	15010	kg *11990	9610	kg *8580	kg 6830	
-3.0 m (-10 ft)	kg *7060	kg *7060	kg *5650	kg *5650	kg *4130	*4130					
	lb	lb	kg *15560	kg *15560	kg *12460	*12460	kg *9110	*9110			

1. Lifting capacity are based on SAE J1097 and ISO 10567.

2. Lifting capacity of the ROBEX series does not exceed 75% of tipping load with the machine on firm, level ground or 87% of full hydraulic capacity.

3. The load point is a hook (standard equipment) located on the back of the bucket.

4. (*) indicates load limited by hydraulic capacity.











LIFTING CAPACITY

HX235 LCR

 Rating over-front  Rating over-side or 360 degrees

HX235 LCR 2-PIECE BOOM

Boom: 5.65 m (18' 6") / Arm: 2.92 m (9' 7") / Bucket: 0.80 m³ (1.05 yd³) SAE heaped / Shoe: 600 mm (24") triple grouser. Dozer Blade down

Load point height m (ft)	Load radius								At max. reach		Reach m (ft)
	3.0 m (10 ft)		4.5 m (15 ft)		6.0 m (20 ft)		7.5 m (25 ft)		Capacity		
											
9.0 m (30 ft)	kg *4950	kg *4950	kg *3120	kg *3120					kg *4630	kg *4630	6.19 (20.3)
	lb *10910	lb *10910	lb *6880	lb *6880					lb *10210	lb *10210	
7.5 m (25 ft)			kg *4750	kg *4750	kg *3400	kg *3400			kg *4050	kg 3340	7.75 (25.4)
			lb *10470	lb *10470	lb *7500	lb *7500			lb *8930	lb 7360	
6.0 m (20 ft)	kg *4760	kg *4760	kg *5190	kg *5190	kg *4840	kg *4840	kg *2180	kg *2180	kg *3820	kg 2610	8.71 (28.6)
	lb *10490	lb *10490	lb *11440	lb *11440	lb *10670	lb *10670	lb *4810	lb *4810	lb *8420	lb 5750	
4.5 m (15 ft)	kg *6690	kg *6690	kg *6760	kg *6760	kg *5420	kg 5040	kg *4250	kg 3360	kg *3650	kg 2240	9.29 (30.5)
	lb *14750	lb *14750	lb *14900	lb *14900	lb *11950	lb 11110	lb *9370	lb 7410	lb *8050	lb 4940	
3.0 m (10 ft)	kg *12100	kg *12100	kg *7760	kg 7560	kg *5820	kg 4730	kg *4670	kg 3220	kg *3430	kg 2060	9.56 (31.4)
	lb *26680	lb *26680	lb *17110	lb 16670	lb *12830	lb 10430	lb *10300	lb 7100	lb *7560	lb 4540	
1.5 m (5 ft)	kg *9380	kg *9380	kg *8470	kg 6870	kg *6110	kg 4400	kg *4710	kg 3060	kg *3180	kg 2010	9.56 (31.4)
	lb *20680	lb *20680	lb *18670	lb 15150	lb *13470	lb 9700	lb *10380	lb 6750	lb *7010	lb 4430	
Ground Line	kg *9730	kg *9730	kg *8370	kg 6450	kg *6040	kg 4160	kg *4520	kg 2930	kg *2850	kg 2100	9.29 (30.5)
	lb *21450	lb *21450	lb *18450	lb 14220	lb *13320	lb 9170	lb *9960	lb 6460	lb *6280	lb 4630	
-1.5 m (-5 ft)	kg *9980	kg *9980	kg *7420	kg 6290	kg *5440	kg 4040	kg *3890	kg 2870	kg *2330	kg *2330	8.71 (28.6)
	lb *22000	lb *22000	lb *16360	lb 13870	lb *11990	lb 8910	lb *8580	lb 6330	lb *5140	lb *5140	
-3.0 m (-10 ft)	kg *7060	kg *7060	kg *5650	kg *5650	kg *4130	kg 4050					
	lb *15560	lb *15560	lb *12460	lb *12460	lb *9110	lb 8930					

1. Lifting capacity are based on SAE J1097 and ISO 10567.

2. Lifting capacity of the ROBEX series does not exceed 75% of tipping load with the machine on firm, level ground or 87% of full hydraulic capacity.

3. The load point is a hook (standard equipment) located on the back of the bucket.

4. (*) indicates load limited by hydraulic capacity.

ENGINE	STD	OPT
Cummins QSB 6.7 engine	●	
HYDRAULIC SYSTEM		
Intelligent Power Control (IPC)		
3-power mode, 2-work mode, user mode	●	
Variable Power Control	●	
Pump Flow Control	●	
Attachment Mode Flow Control		●
Engine Auto Idle	●	
Engine Auto Shutdown Control		●
Electronic Fan Control	●	
CABIN & INTERIOR		
ISO Standard cabin		
Rise-up type windshield wiper	●	
Radio / USB player	●	
Handsfree mobile phone system with USB	●	
12 volt power outlet (24V DC to 12V DC converter)	●	
Electric horn	●	
All-weather steel cab with 360° visibility	●	
Safety glass windows	●	
Sliding fold-in front window	●	
Sliding side window (LH)	●	
Lockable door	●	
Hot & cool box	●	
Storage compartment & Ashtray	●	
Transparent cabin roof-cover	●	
Sun visor	●	
Door and cab locks, one key	●	
Mechanical suspension seat with heater	●	
Pilot-operated slidable joystick	●	
Console box height adjust system	●	
Automatic climate control		
Air conditioner & heater	●	
Defroster	●	
Starting Aid (air grid heater) for cold weather	●	
Centralized monitoring		
8" LCD display	●	
Engine speed or Trip meter/Accel.	●	
Engine coolant temperature gauge	●	
Max power	●	
Low speed/High speed	●	
Auto idle	●	
Overload	●	
Check Engine	●	
Air cleaner clogging	●	
Indicators	●	
ECO Gauges	●	
Fuel level gauge	●	
Hyd. oil temperature gauge	●	
Fuel warmer	●	
Warnings	●	
Communication error	●	
Low battery	●	
Clock	●	
Cabin lights		●
Cabin front window rain guard	●	
Cabin roof-steel cover		●
Seat		
Adjustable air suspension seat with heater		●
Cabin FOPS/FOG (ISO/DIS 10262) Level 2		
FOPS (Falling Object Protective Structure) · ISO 3449 Level 2		●
FOG (Falling Object Guard)		●
Cabin ROPS (ISO 12117-2)		
ROPS (Roll Over Protective Structure)	●	

SAFETY	STD	OPT
Battery master switch	●	
Rearview camera	●	
Four front working lights	●	
Travel alarm	●	
Rear work lamp		●
Beacon lamp		●
Automatic swing brake	●	
Boom holding system	●	
Arm holding system	●	
Safety lock valve for boom cylinder with overload warning device	●	
Safety lock valve for arm cylinder		●
Swing Lock System		●
Two outside rearview mirrors	●	
OTHER		
Booms		
5.68 m; 18' 8" Mono	●	
5.65 m; 18' 6" 2-Piece		●
Arms		
2.0 m; 6' 7"		●
2.4 m; 7' 10"		●
2.92 m; 9' 7"	●	
Removable clean-out dust net for cooler	●	
Removable reservoir tank	●	
Fuel pre-filter	●	
Fuel warmer (single)	●	
Fuel warmer (dual)		●
Self-diagnostics system	●	
Hi-mate (Remote Management System)	●	
Batteries (2 x 12 V x 100 Ah)	●	
Fuel filler pump (50 l/min)		●
Single-acting piping kit (breaker, etc.)		●
Double-acting piping kit (clamshell, etc.)	●	
Rotating Piping Kit		●
Quick coupler piping		●
One Pedal Straight Travel System		●
Accumulator for lowering work equipment	●	
Pattern change valve (2 patterns)		●
Fine Swing Control System		●
Tool kit		●
UNDERCARRIAGE		
Lower frame under cover (Additional)		●
Lower frame under cover (Normal)	●	
Track shoes		
Triple grouser shoe (600 mm; 24")	●	
Triple grouser shoe (700 mm; 28")		●
Triple grouser shoe (800 mm; 32")		●
Triple grouser shoe (900 mm; 36")		●
Track rail guard	●	

STD = Standard
OPT = Optional

- * Standard and optional equipment may vary. Contact your Hyundai dealer for more information. The machine may vary according to International standards.
- * The photos may include attachments and optional equipment that are not available in your area.
- * Materials and specifications are subject to change without advance notice.
- * All imperial measurements rounded off to the nearest pound or inch.