

TB230



COMPACT EXCAVATOR

takeuchi
Japanese for Reliability

Takeuchi's New 3 tonne TB230 - high performance excavator

The TB230 is a powerful yet compact machine for this popular 3 tonne weight class.

With increased power and performance this new Takeuchi provides maximum efficiency on site - featuring many new details, the new TB230 is built for plant hire, groundworks and earthmoving.

The TB230 combines all the proven characteristics of Takeuchi excavators - smooth hydraulics, powerful machine performance and good serviceability in a brand new 3 tonne excavator.

3 TONNE POWER PERFORMANCE

The TB230 offers maximum performance with excellent bucket breakout force of 20.9kN and 12.9kN arm digging force, powered by a 17.6kW Yanmar 3 cylinder engine.

Compact in size - the TB230 has a track footprint of just 1460 x 1900mm.

The new TB230 has plenty of power and greater torque along with a well proven, high performance hydraulic system for greater oil flow for faster cycle times and increased efficiency.

NEW STYLED CAB

The newly designed 3 tonne has the new stylish cab as seen on larger Takeuchi machines.

Large and comfortable with excellent all-round visibility and maximum operator accessibility. The well positioned colour VDU illuminates all the active operating switch functions.

Standard features include top window with sun shade, MP3 socket, adjustable high back seat and arm rests.



HEAVY DUTY DOZER

A heavy duty dozer blade with well protected cylinder comes as standard - built for tough terrains with an increased operating range.





RELIABILITY & SERVICEABILITY

The new TB230 has maximum accessibility for daily routine service. The large wide opening covers are accessed without any tools required.

The TB230 has well protected hydraulic hoses across the entire machine.

Boom and arm holding valves as standard to maintain load control when lifting if hoses fail.



PERFORMANCE

- Excellent dig depth to 2835mm and ground reach 4710mm.
- Proven strong track frame design offers excellent balance and stability with a longer than average track frame (1440mm).
- Two speed tracking with auto step down when dozing.
- Auxiliary hoses are easy to attach and well positioned high up the dipper arm for added protection.
- Triple flange rollers for superior track retention.

OPERATION

- Compact size with slew radius of just 1330mm, added offset position RH 58° and LH 79°.
- Cushioned main boom and swing cylinders for smooth operation.
- Boom and cab mounted work light for all types of working conditions.
- Well positioned enhanced Colour VDU - warning indicators, rpm, hour meter, fuel, battery charge, temperature, oil pressures and maintenance alerts.
- Hydraulic detent mode (Service port 1) for attachments requiring continuous hydraulic flow.

SAFETY & SERVICE

- Enhanced 100% steel wraparound frame protects all the key components. Flat glass panels make replacement an affordable option.
- Easy access to all service points around the machine.
- Standard service features include: safe drain engine oil system, fuel gauge at filler and in cab, fuel drain system, hydraulic oil cooler and maintenance free battery.



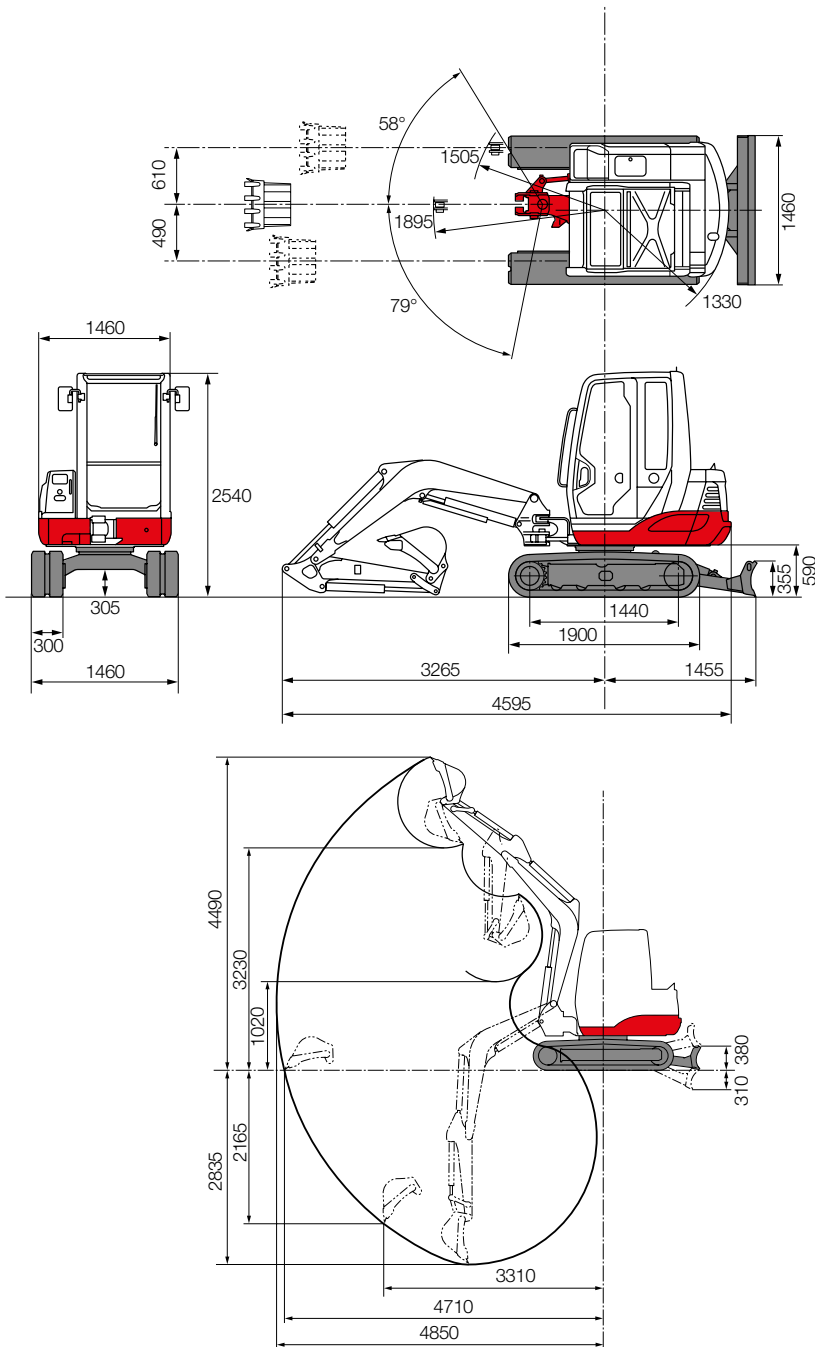

For more information locally

call us direct, or contact:



Takeuchi Mfg (UK) Ltd, Unit E2B Kingsway Business Park,
John Boyd Dunlop Drive, Rochdale, Lancashire OL16 4NG
Tel: 01706 657 722 Fax: 01706 657 744

Southern Depot at 20 Colthrop Business Park
Colthrop Lane, Thatcham, Newbury, Berks RG19 4NB
Tel: 01635 877 196 Fax: 01635 877 195

www.takeuchi-mfg.co.uk Email: sales@takeuchi-mfg.co.uk

TB230 Standard UK Specification Long Arm/Rubber Tracks

Engine	
Make	YANMAR
Model	3TNV88F
Rated Output (kW)/rpm	17.6/2400
Maximum Torque (Nm)	93.4-92.2
Cylinders	3
Displacement (cc)	1642
Electrical System	12 volt 54 amp

Dimensions & Weight	
Operating Weight inclusive of bucket and fuel (kg)	2885/2950
Overall Length (mm) for transport	4595
Width (mm)	1460
Height (mm)	2540
Ground Clearance (mm)	305
Min. Front Swing Radius (mm)	1505
Slew Radius (mm)	1330
Dozer Blade (W x H) (mm)	1450 x 355

Operating Information	
Max Digging Depth (mm)	2835
Max Dump Height (mm)	3230
Max Reach at Ground Level (mm)	4710
Max Vertical Digging Depth (mm)	2165
Max Bucket Digging Force (kN)	20.9
Max Arm Digging Force (kN)	12.9

Hydraulic System	
Set Pressure (bar)	210
Pump Type	Variable x 2 + Gear x 2
Hydraulic Flow Aux Port (l/min)	54

Swing System	
Boom Swing Angle (L/R)	79°/58°
Slew Speed (rpm)	10.3
Slew Motor	Piston
Slew Brake	Disc

Undercarriage	
Traction Motor	Variable Displacement Motor
Traction Drive	Epicyclic Gearing
Traction Brake	Disc
Track Width (mm)	300
Ground Contact Length (mm)	1440
Ground Pressure (kpa)	30.1
Travel Speed (km/h)	2.9/5.2
Maximum Gradeability	30°

Capacities	
Hydraulic System (l)	56
Fuel Tank (l)	46
Engine Lubrication (l)	4.7
Cooling System (l)	4

OPTIONS: TKB102-S hydraulic breaker, hitches and bucket sizes from 150 - 1000mm.

09/2016

Takeuchi machines come with a 2 year/2000 hours warranty as standard. Warranty exceptions to 1 year; fuel injection systems, electrical components, paint work.

In accordance with our established policy of constant improvement, we reserve the right to amend these specifications at any time without notice. Photographs shown may feature non-standard equipment.

TAKEUCHI
Japanese for Reliability